

EMC TEST REPORT

For

**Shenzhen Xiaohe Technology Co., Ltd
Spring Sleeping Instrument**

Model No. : HE-M001

**Prepared for : Shenzhen Xiaohe Technology Co., Ltd
Address : 403, Building C And D, Yingkeli Industrial Park, No. 6, Inner Ring
North Road, Longxin Community, Baolong Street, Longgang
District, Shenzhen**

**Prepared By : Shenzhen SAIL Testing Technology Co.,Ltd
Address :Room 301, 3 / F, Miyungu AI Center, Block B, Wuzhou
Xintiandi, 6038 Longgang Avenue,Shenzhen,P.R.China**

**Report Number :HZE200608-3949
Date of Test :June 3, 2020
Date of Report :June 8, 2020**

TABLE OF CONTENTS

<u>Description</u>	<u>Page</u>
Test Report Declaration.....	5
1. Summary of standards and results.....	6
1.1. Description of Standards and Results.....	6
2. GENERAL INFORMATION.....	7
2.1. Description of Device (EUT).....	7
2.2. Block Diagram of connection between EUT and simulators.....	7
2.3. Laboratory Name:.....	8
2.4. Site Location.....	8
2.5. Test Facility.....	8
2.6. Measurement Uncertainty.....	8
3. Conducted Disturbance at Mains Terminals test.....	9
3.1. Test Equipment.....	9
3.2. Block Diagram of Test Setup.....	9
3.3. Conducted Disturbance at Mains Terminals Test Standard and Limit.....	9
3.4. EUT Configuration on Test.....	10
3.5. Operating Condition of EUT.....	10
3.6. Test Procedure.....	10
3.7. Conducted Disturbance at Mains Terminals Test Results.....	10
4. Disturbance POWER test.....	11
4.1. Test Equipment.....	11
4.2. Block Diagram of Test Setup.....	11
4.3. Disturbance Power Test Standard and Limit.....	11
4.4. EUT Configuration on Test.....	12
4.5. Operating Condition of EUT.....	12
4.6. Test Procedure.....	12
4.7. Disturbance Power Test Result.....	12
5. Radiated Disturbance test.....	13
5.1. Test Equipment.....	13
5.2. Block Diagram of Test Setup.....	13
5.3. Test Standard.....	13
5.4. Radiated Disturbance Limit.....	13
5.5. EUT Configuration on Test.....	14
5.6. Operating Condition of EUT.....	14
5.7. Test Procedure.....	14
5.8. Test result.....	15
6. clicks.....	18

7. harmonic CURRENT TEST.....	19
7.1. Test Equipment.....	19
7.2. Block Diagram of Test Setup.....	19
7.3. Harmonics Test Standard.....	19
7.4. Limits of Harmonic Current.....	19
7.5. Operating Condition of EUT.....	20
7.6. Test Procedure.....	20
7.7. Test Results.....	20
8. VOLTAGE FLUCTUATIONS & FLICKER TEST.....	21
8.1. Test Equipment.....	21
8.2. Block Diagram of Test Setup.....	21
8.3. Voltage Fluctuation and Flicker Test Standard.....	21
8.4. Limits of Voltage Fluctuation and Flick.....	21
8.5. Operating Condition of EUT.....	21
8.6. Test Procedure.....	21
8.7. Test Results.....	21
9. Immunity Performance Criteria Description.....	22
10. Electrostatic Discharge TEST.....	23
10.1. Test Equipment.....	23
10.2. Block Diagram of Test Setup.....	23
10.3. Test Standard.....	23
10.4. Severity Levels and Performance Criterion.....	23
10.5. EUT Configuration.....	23
10.6. Operating Condition of EUT.....	24
10.7. Test Procedure.....	24
10.8. Test Results.....	24
11. RF Field Strength susceptibility Test.....	26
11.1. Test Equipment.....	26
11.2. Block Diagram of Test Setup.....	26
11.3. Test Standard.....	27
11.4. Severity Levels and Performance Criterion.....	27
11.5. EUT Configuration.....	27
11.6. Operating Condition of EUT.....	27
11.7. Test Procedure.....	27
11.8. Test Results.....	28
12. Electrical Fast Transient/Burst Test.....	30
12.1. Test Equipment.....	30
12.2. Block Diagram of Test Setup.....	30
12.3. Test Standard.....	30
12.4. Severity Levels and Performance Criterion.....	30
12.5. EUT Configuration.....	30
12.6. Operating Condition of EUT.....	31

127. Test Procedure.....	31
128. Test Result.....	31
13. SURGE Test.....	32
131. Test Equipment.....	32
132. Block Diagram of Test Setup.....	32
133. Test Standard.....	32
134. Severity Levels and Performance Criterion.....	32
135. EUT Configuration.....	32
136. Operating Condition of EUT.....	33
137. Test Procedure.....	33
138. Test Result.....	33
14. Injected currents susceptibility test.....	34
141. Test Equipment.....	34
142. Block Diagram of Test Setup.....	34
143. Test Standard.....	34
144. Severity Levels and Performance Criterion.....	35
145. EUT Configuration.....	35
146. Operating Condition of EUT.....	35
147. Test Procedure.....	35
148. Test Results.....	35
15. Voltage dips and interruptions test.....	36
151. Test Equipment.....	36
152. Block Diagram of Test Setup.....	36
153. Test Standard.....	36
154. Severity Levels and Performance Criterion.....	36
155. EUT Configuration.....	36
156. Operating Condition of EUT.....	37
157. Test Procedure.....	37
158. Test Result.....	37
16. Photos of the EUT.....	38

TEST REPORT DECLARATION

Applicant : Shenzhen Xiaohe Technology Co., Ltd

Manufacturer : Shenzhen Xiaohe Technology Co., Ltd

Description : Spring Sleeping Instrument

(A) Model No. : HE-M001

(B) Trademark : N/A

(C) Test Voltage : DC 5V

Measurement Standard Used:

EN 55014 -1: 2017

EN 61000-3-2: 2014, EN 61000-3-3: 2013

EN 55014 -2:2015

(IEC61000-4-2:2008; IEC 61000-4-3:2006+A1:2007+A2:2010; IEC 61000-4-4:2012;
IEC 61000-4-5:2014; IEC61000-4-6:2013; IEC61000-4-11:2004)

The device described above is tested by Shenzhen Hong Testing technology Co., Ltd to determine the maximum emission levels emanating from the device and the severe levels of the device can endure and its performance criterion. The test results are contained in this test report and Shenzhen Hong Testing technology Co., Ltd is assumed full responsibility for the accuracy and completeness of test. Also, this report shows that the EUT is technically compliant with the EN 55014-1, EN 61000-3-2, EN 61000-3-3 and EN 55014-2 requirements.

This report applies to above tested sample only. This report shall not be reproduced in part without written approval of

Tested by (name + signature)..... :Chael Liang

Test Engineer

Approved by (name + signature).....:Tom Zhu

Project Manage

Date of issue.....:June 8, 2020

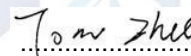

1. SUMMARY OF STANDARDS AND RESULTS

1.1. Description of Standards and Results

The EUT have been tested according to the applicable standards as referenced below.

EMISSION				
Description of Test Item	Standard	Limits		Results
Conducted disturbance at mains terminals test	EN55014-1: 2017	Section 4.1.1		N/A
Disturbance power test	EN55014-1: 2017	Section 4.1.2		N/A
Radiated disturbance	EN55014-1: 2017	Section 9		PASS
Harmonic current emissions	EN 61000-3-2: 2014	Class A		N/A
Voltage fluctuations & flicker	EN 61000-3-3: 2013	Section 5		N/A
Clicks	EN55014-1: 2017	Section 4.2		N/A
IMMUNITY (EN 55014 -2:2015)				
Description of Test Item	Basic Standard	Performance Criteria	Observation Criteria	Results
Electrostatic discharge (ESD)	IEC 61000-4-2: 2008	B	A	PASS
Radio-frequency, Continuous radiated disturbance	IEC 61000-4-3: 2006+A1:2007+A2:2010	A	A	PASS
Electrical fast transient (EFT)	IEC 61000-4-4:2012	B	A	N/A
Surge (Input a.c. power ports)	IEC 61000-4-5:2014	B	A	N/A
Radio-frequency, Continuous conducted disturbance	IEC61000-4-6:2013	A	A	N/A
Voltage dips, Interruptions	IEC61000-4-11:2004	C	A&B	N/A
N/A is an abbreviation for Not Applicable.				

2. GENERAL INFORMATION

2.1. Description of Device (EUT)

Description : Spring Sleeping Instrument

Model Number : HE-M001
DIFF. :

Trademark : N/A

Applicant : Shenzhen Xiaohe Technology Co., Ltd
Address : 403, Building C And D, Yingkeli Industrial Park,
No. 6, Inner Ring North Road, Longxin
Community, Baolong Street, Longgang District,
Shenzhen

Manufacturer : Shenzhen Xiaohe Technology Co., Ltd
Address : 403, Building C And D, Yingkeli Industrial Park,
No. 6, Inner Ring North Road, Longxin
Community, Baolong Street, Longgang District,
Shenzhen

Sample Type : Prototype production

2.2. Block Diagram of connection between EUT and simulators



※ EUT: Spring Sleeping Instrument

2.3. Laboratory Name:

2.4. Site Location :

3F,JinHai building 2, JinHai road XiXiang street Baoan district ShenZhen , P.R. China

2.5. Test Facility

JAN 01, 2012 File on Federal Communication Commission
Registration Number:177635

September 11, 2011 Certificated by IC
Registration Number: 8513 B

2.6. Measurement Uncertainty
(95% confidence levels, k=2)

Test Item	Uncertainty	U _{cispr}
Uncertainty for Conduction emission test	2.50dB	3.8 dB
Uncertainty for Radiation Emission test	3.04 dB (Distance: 3m Polarize: V)	5.2 dB
	3.02 dB (Distance: 3m Polarize: H)	
Uncertainty for Flicker test	0.05%	N/A
Uncertainty for Harmonic test	1.8%	N/A

3. CONDUCTED DISTURBANCE AT MAINS TERMINALS TEST

3.1. Test Equipment

Item	Equipment	Manufacturer	Model No.	Serial No.	Last Cal.	Cal. Interval
1.	Test Receiver	Rohde&Schwarz	ESCI	100843	Sep.19, 18	1 Year
2.	L.I.S.N.#1	Schwarzbeck	NSLK8126	8126466	Sep.19, 18	1 Year
3.	Terminator	Hubersuhner	50Ω	No. 1	Sep.19, 18	1 Year
4.	RF Cable	Schwarzbeck	9111505/200	5995-12-161-6890#	Sep.19, 18	1 Year
5.	Coaxial Switch	Schwarzbeck	CX-210	N/A	Sep.19, 18	1 Year
6.	Pulse Limiter	Schwarzbeck	VTSD9516F	9618	Sep.19, 18	1 Year

3.2. Block Diagram of Test Setup

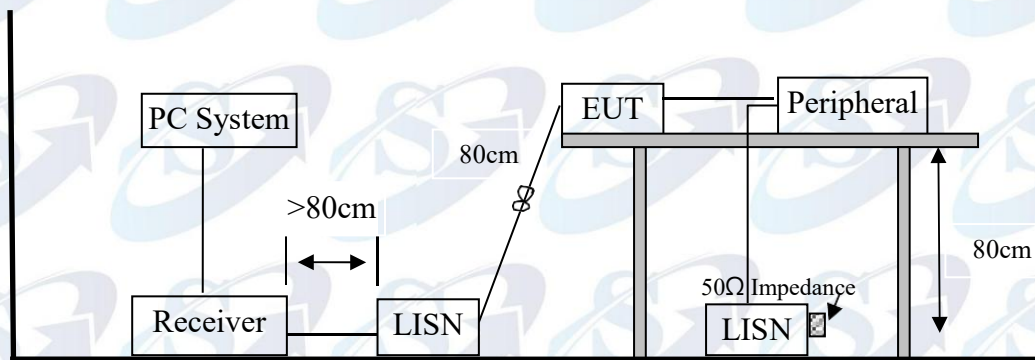

3.3. Conducted Disturbance at Mains Terminals Test Standard and Limit

3.3.1. Test Standard

EN 55014 -1: 2017

3.3.2. Test Limit

Frequency	At mains terminals (dBμV)	
	Quasi-peak Level	Average Level
150kHz ~ 500kHz	66 ~ 56 *	59 ~ 46 *
500kHz ~ 5MHz	56	46
5MHz ~ 30MHz	60	50

Notes: 1. Emission level=Read level+LISN factor-Preamp factor+Cable loss

2* Decreasing linearly with logarithm of frequency.

3. The lower limit shall apply at the transition frequencies.

3.4. EUT Configuration on Test

The following equipment are installed on conducted disturbance at mains terminals to meet EN 55014-1 requirement and operating in a manner which tends to maximize its emission characteristics in a normal application.

3.5. Operating Condition of EUT

3.5.1. Setup the EUT as shown in section 3.2.

3.5.2. Turned on the power of all equipment.

3.5.3. Let the EUT worked in test mode and measure it.

3.6. Test Procedure

The EUT was placed on a non-metallic table, 80cm above the ground plane. The EUT Power connected to the power mains through a line impedance stabilization network (L.I.S.N. #1). The power line was checked for maximum conducted interference. In order to find the maximum emission, the relative positions of equipment and all of the interface cables were changed according to EN 55014-1 on Conducted Disturbance at Mains Terminals test.

The bandwidth of test receiver (R & S ESCI) is set at 10kHz.

The frequency range from 150kHz to 30MHz is checked. The test result are reported on Section 3.7.

3.7. Conducted Disturbance at Mains Terminals Test Results

N/A

The EUT is supplied by battery, so this item does not applicable.

4. DISTURBANCE POWER TEST

4.1. Test Equipment

Item	Equipment	Manufacturer	Model No.	Serial No.	Last Cal.	Cal. Interval
7.	Test Receiver	Rohde & Schwarz	ESCI	100843	Sep.19, 18	1 Year
8.	Absorbing Clamp	Liithi	MDS-21	4054	Sep.19, 18	1 Year
9.	N50(f-m) 6dB Fixed Attenuator	Agilent	8491A	MY39264395	Sep.19, 18	1 Year
10.	RF Cable	MIYAZAKI	5D-2W	NO.1	Sep.19, 18	1 Year

4.2. Block Diagram of Test Setup

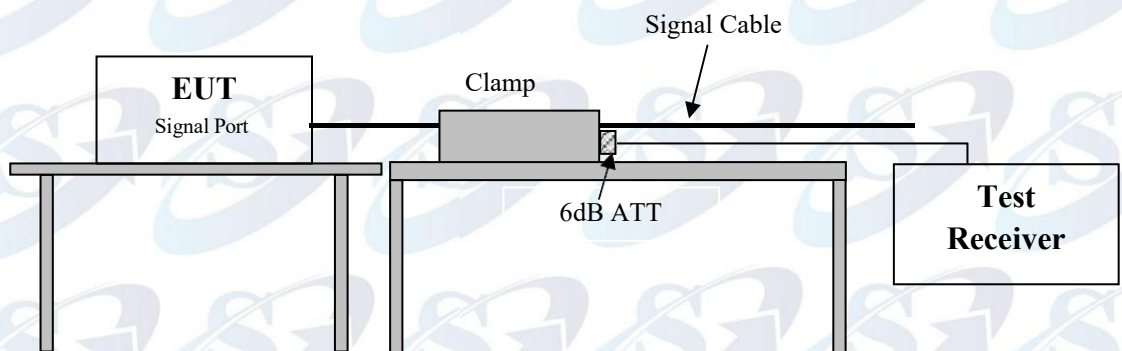

4.3. Disturbance Power Test Standard and Limit

4.3.1. Test Standard

EN 55014 -1: 2017

4.3.2. Test Limit

All emanations from devices or system including any network of conductors and apparatus connected thereto, shall not exceed the level of field strengths specified below:

Frequency MHz	Interference Power Limits (dBpW)	
	Quasi-peak Value	Average Value
30 ~ 300	45 Increasing Linearly with Frequency to 55	35 Increasing Linearly with Frequency to 45

Emission level=Read level+LISN factor-Preamp factor+Cable loss

4.4. EUT Configuration on Test

The EN55014-1 regulations test method must be used to find the maximum emission during radiated power test. Any lead connecting the EUT to an auxiliary apparatus is disconnected if this does not affect the operation of the EUT, or is isolated by means of absorbing clamp close to the EUT, a similar measure was made on each lead which is or may be connected to an auxiliary apparatus, whether or not it is necessary for the operation of the EUT.

4.5. Operating Condition of EUT

Same as conducted test which is listed in section 3.6. except the test setup replaced by section 4.2.

4.6. Test Procedure

The EUT is placed on the table which is high 0.8m by insulating support and away from other metallic surface at least 0.8m. It is connected to the power mains through an extension cord of 6m minimums. The absorber clamp was clamps the cord and moves from the far end to EUT to measure the disturbing energy emitted from the cord.

The bandwidth of the field strength meter (Rohde&Schwarz Test Receiver ESCI) is set at 120kHz.

The frequency range from 30MHz to 300MHz is checked. All the test results are listed in Section 4.7.

4.7. Disturbance Power Test Result

N/A

The EUT has no cable out, so this item does not applicable.

5. RADIATED DISTURBANCE TEST

5.1. Test Equipment

5.1.1. For frequency range 30MHz~1000MHz (At Semi Anechoic Chamber)

Item	Equipment	Manufacturer	Model No.	Serial No.	Last Cal.	Cal. Interval
1	Test Receiver	Rohde&Schwarz	ESCI	101165	Sep.19, 18	1 Year
2	Amplifier	Schwarzbeck	BBV9743	9743-019	Sep.19, 18	1 Year
3	Bilog Antenna	Schwarzbeck	VULB9168	VULB9168-438	Sep.19, 18	1 Year
4	RF Cable	Schwarzbeck	AK9515E	95891-2m	Sep.19, 18	1 Year
5	RF Cable	Schwarzbeck	AK9515E	95891-11m	Sep.19, 18	1 Year
6	RF Cable	Schwarzbeck	AK9515E	95891-0.5m	Sep.19, 18	1 Year

5.2. Block Diagram of Test Setup

5.2.1. In Semi Anechoic Chamber (3m) Test Setup Diagram for 30MHz~1000MHz

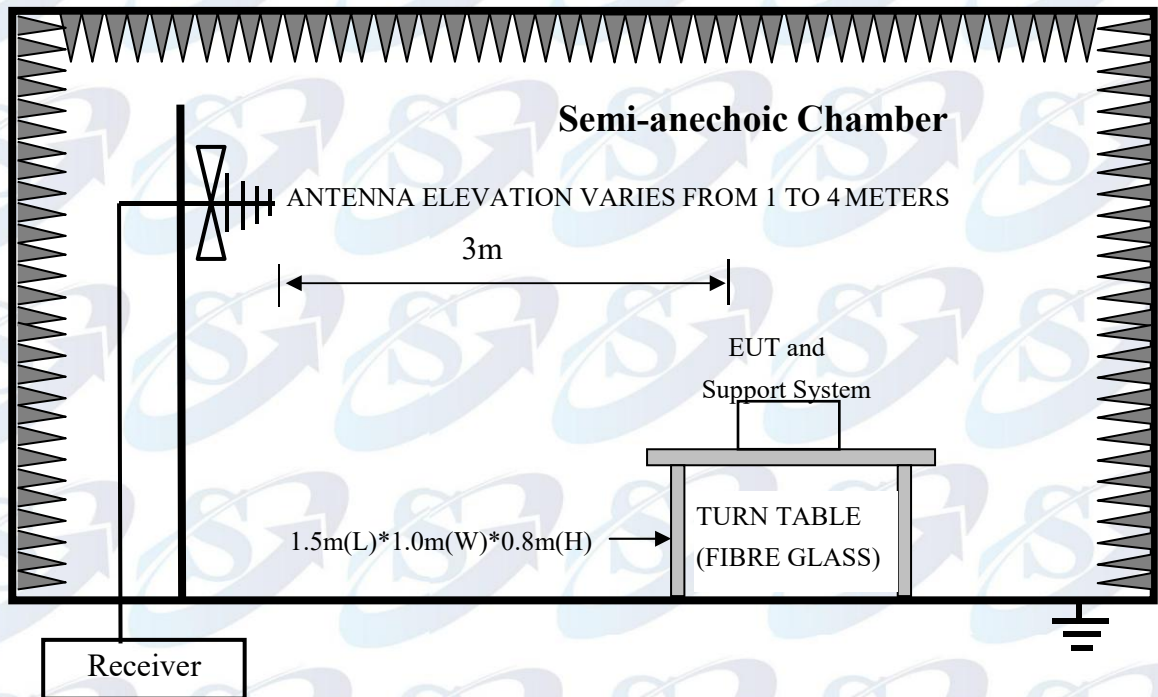

5.3. Test Standard

EN55014-1: 2017

5.4. Radiated Disturbance Limit

All emanations from a Class B computing devices or system, including any network of conductors and apparatus connected thereto, shall not exceed the level of field strengths specified below:

FREQUENCY (MHz)	DISTANCE (Meters)	FIELD STRENGTHS LIMITS (dB μ V/m)
30 ~ 230	3	40
230 ~ 1000	3	47

Note: (1) Emission level = Read level+Antenna Factor-Preamp Factor +Cable Loss
(2) The lower limit shall apply at the transition frequencies.
(3) Distance refers to the distance in meters between the test instrument antenna and the closed point of any part of the E.U.T.

5.5. EUT Configuration on Test

The EN 55014-1 regulations test method must be used to find the maximum emission during Radiated Disturbance test. The configuration of EUT is same as used in Conducted Disturbance test. Please refer to Section 3.5.

5.6. Operating Condition of EUT

5.6.1. Setup the EUT and simulator as shown as Section 5.2.

5.6.2. Turned on the power of all equipment.

5.6.3. Let the EUT work in test mode (Working) and measure it.

5.7. Test Procedure

The EUT was placed on a non-metallic table, 80 cm above the ground plane inside a semi-anechoic chamber. An antenna was located 3m & 3m from the EUT on an adjustable mast. A pre-scan was first performed in order to find prominent radiated emissions. For final emissions measurements at each frequency of interest, the EUT were rotated and the antenna height was varied between 1m and 4m in order to maximize the emission. Measurements in both horizontal and vertical polarities were made and the data was recorded. In order to find the maximum emission, the relative positions of equipment and all the interface cables were changed according to EN 55014 on Radiated Disturbance test.

The bandwidth setting on the test receiver (Rohde&Schwarz Test Receiver ESCI) is 120 kHz.

5.8. Test result

PASS. (All emissions not reported below are too low against the prescribed limits.)

For frequency range 30MHz~1000MHz

The EUT with the following test mode was tested and read Q.P values, the test results are listed in next pages.

Temperature: 24℃ Humidity: 54%

The details of test mode is as follows :

No.	Test Mode
1.	Working

80.0 dBuV/m



Site : 966 Chamber

Polarization: **Vertical**

Temperature: 24.3

Limit: EN55014 ClassB 3M Radiation

Power:

Humidity: 66 %

EUT: 4#

Distance: 3m

M/N:

Mode:

Note:

No. Mk.	Freq. MHz	Reading Level dBuV	Correct Factor dB	Measurement dBuV/m	Limit dB/	Margin dB	Detector	Antenna Height cm	Table Degree degree	Comment
1	49.8382	31.66	-13.58	18.08	40.00	-21.92	peak			
2 *	112.7902	39.63	-9.05	30.58	40.00	-9.42	peak			
3	274.8180	33.55	-12.99	20.56	47.00	-26.44	peak			

80.0 dBuV/m



Site : 966 Chamber

Polarization: **Horizontal**

Temperature: 24.3

Limit: EN55014 ClassB 3M Radiation

Power:

Humidity: 66 %

EUT: 4#

Distance: 3m

M/N:

Mode:

Note:

No.	Mk.	Freq. MHz	Reading Level dBuV	Correct Factor dB	Measure- ment dBuV/m	Limit dB/	Margin dB	Detector	Antenna Height cm	Table Degree degree	Comment
1	*	111.2396	38.58	-16.90	21.68	40.00	-18.32	peak			
2		274.8180	39.31	-13.49	25.82	47.00	-21.18	peak			

6. CLICKS

The EUT which fulfil the following condition:

- the click rate is no more than 5;
- none of the caused clicks has duration longer than 20 ms,
- 90% of the caused clicks have a duration less than 10 ms (measured duration time is 0.4ms), was deemed to comply with the limits.

The disturbance from individual switching operations, caused directly or indirectly, manually or by similar activities on a switch or a control which is included in an appliance or otherwise to be used for:

- a) the purpose of mains connection or disconnection only;
- b) the purpose of programme selection only;
- c) the control of energy or speed by switching between a limited number of fixed positions;
- d) the changing of the manual setting of a continuously adjustable control such as a variable speed device for water extraction or electronic thermostats, is to be disregarded for the purpose of testing the appliance for compliance with the limits of radio disturbance set out in this standard.

Also the disturbance caused by the operation of any switching device or control which is included in an appliance for the purpose of mains disconnection for safety only, is to be disregarded for the purpose of testing the appliance for compliance with the limits of radio disturbance as described in this standard.

7. HARMONIC CURRENT TEST

7.1. Test Equipment

Item	Equipment	Manufacturer	Model No.	Serial No.	Last Cal.	Cal. Interval
1.	Harmonics&Flicker Analyser	Voltech	PM6000	2000067 00495	Sep.19, 18	1 Year

7.2. Block Diagram of Test Setup

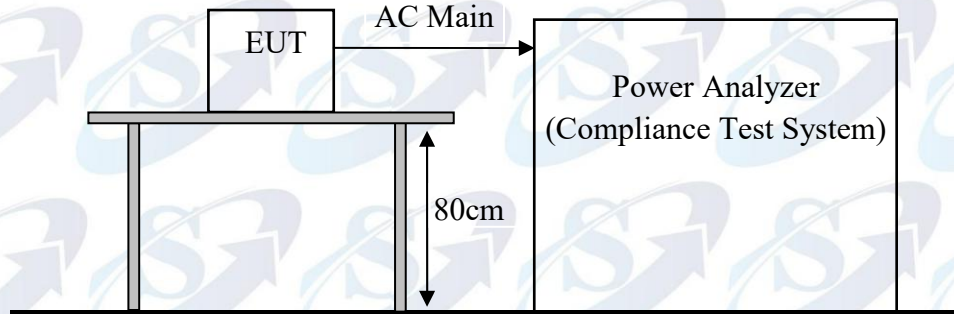

7.3. Harmonics Test Standard

EN 61000-3-2: 2014, Class A

7.4. Limits of Harmonic Current

Limits for Class A equipment	
Harmonic order n	Maximum permissible Harmonic current A
Odd harmonics	
3	2,30
5	1,14
7	0,77
9	0,40
11	0,33
13	0,21
$15 \leq n \leq 39$	$0,15 \frac{15}{n}$
Even harmonics	
2	1,08
4	0,43
6	0,30
$8 \leq n \leq 40$	$0,23 \frac{8}{n}$

7.5. Operating Condition of EUT

Same as section 3.6. except the test set up replaced by section 7.2..

7.6. Test Procedure

The EUT was placed on the top of a wooden table 0.8 meters above the ground and operated to produce the maximum harmonic components under normal operating conditions for each successive harmonic component in turn. The correspondent test program of test instrument to measure the current harmonics emanated from EUT is chosen. The measure time shall be not less than the necessary for the EUT to be exercised.

7.7. Test Results

The EUT is supplied by battery, so this item does not applicable.

8. VOLTAGE FLUCTUATIONS & FLICKER TEST

8.1. Test Equipment

Same as Section 7.1.

8.2. Block Diagram of Test Setup

Same as Section 7.2.

8.3. Voltage Fluctuation and Flicker Test Standard

EN 61000-3-3: 2013

8.4. Limits of Voltage Fluctuation and Flick

Test Item	Limit	Note
P_{st}	1.0	P_{st} means Short-term flicker indicator
P_{lt}	0.65	P_{lt} means long-term flicker indicator
T_{dt}	0.2	T_{dt} means maximum time that dt exceeds 3%
$d_{max}(\%)$	4%	d_{max} means maximum relative voltage change.
$d_c(\%)$	3%	d_c means relative steady-state voltage change.

8.5. Operating Condition of EUT

Same as Section 7.5.

8.6. Test Procedure

The EUT was placed on the top of a wooden table 0.8 meters above the ground and operated to produce the most unfavorable sequence of voltage changes under normal conditions During the flick measurement, the measure time shall include that part of whole operation changes. The observation period for short-term flicker indicator is 10 minutes and the observation period for long-term flicker indicator is 2 hours.

8.7. Test Results

The EUT is supplied by battery, so this item does not applicable.

9. IMMUNITY PERFORMANCE CRITERIA DESCRIPTION

Performance Level

The test results shall be classified in terms of the loss of function or degradation of performance of the equipment under test, relative to a performance level by its manufacturer or the requestor of the test, or the agreed between the manufacturer and the purchaser of the product.

Definition related to the performance level:

1. Based on the used product standard
2. Based on the declaration of the manufacturer, requestor or purchaser

Criterion A:

Definition: normal performance within limits specified by the manufacturer, requestor and purchaser.

The **apparatus** shall continue to operate as intended during the test and after the test. No degradation of performance or loss of function is allowed below a performance level (or permissible loss of performance) specified by the manufacturer, when the apparatus is used as intended. If the minimum performance level or the permissible performance loss is not specified by the manufacturer, then either of these may be derived from the product description and documentation, and from what the user may reasonably expect from the apparatus if used as intended.

Criterion B:

Definition: temporary loss of function or degradation of performance which ceases after the disturbance ceases, and from which the equipment under test recovers its normal performance, without operator intervention.

The apparatus shall continue to operate as intended after the test. No degradation of performance or loss of function is allowed below a performance level (or permissible loss of performance) specified by the manufacturer, when the apparatus is used as intended. The performance level may be replaced by a permissible loss of performance. During the test, degradation of performance is allowed, however. No change of actual operation state or stored data is allowed. If the minimum performance level or the permissible performance loss is not specified by the manufacturer, then either of these may be derived from the product description and documentation, and from what the user may reasonably expect from the apparatus the apparatus if used as intended.

Criterion C:

Definition: temporary loss of function or degradation of performance, the correction of which requires operator intervention.

Temporary loss of function is allowed, provided the function is self-recoverable or can be restored by the operation of the controls, or by any operation specified in the instructions for use.

Criterion D:

Definition: loss of function or degradation of performance, which is not recoverable, owing to damage to hardware or software, or loss of data.

10. ELECTROSTATIC DISCHARGE TEST

10.1. Test Equipment

Item	Equipment	Manufacture r	Model No.	Serial No.	Last Cal.	Cal. Interval
1.	ESD Tester	HAEFLY	PESAX61 0	H310546	Sep.19, 18	1 Year

10.2. Block Diagram of Test Setup

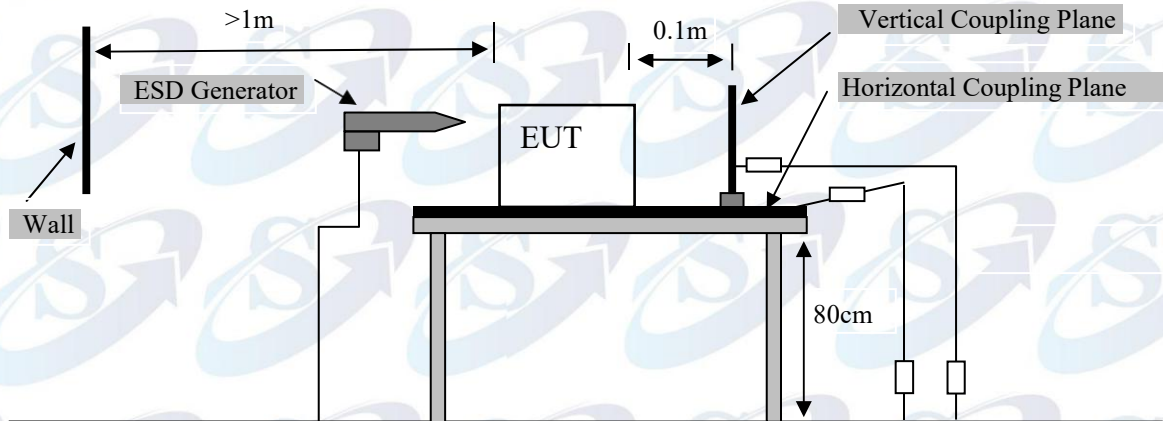

10.3. Test Standard

EN 55014 -2: 2015 (IEC61000-4-2: 2008)
 (Severity Level 1&2&3 for Air Discharge at 2kV&4kV&8kV,
 Severity Level 1&2 for Contact Discharge at 2kV&4kV)

10.4. Severity Levels and Performance Criterion

10.4.1. Severity level

Level	Test Voltage Contact Discharge (kV)	Test Voltage Air Discharge (kV)
1.	2	2
2.	4	4
3.	6	8
4.	8	15
X	Special	Special

10.4.2. Performance criterion: **B**

10.5. EUT Configuration

The configuration of EUT are listed in section 3.5.

10.6. Operating Condition of EUT

Same as conducted test which is listed in section 3.6. except the test setup replaced by section 10.2.

10.7. Test Procedure

10.7.1. Air Discharge:

The test was applied on non-conductive surfaces of EUT. The round discharge tip of the discharge electrode was approached as fast as possible to touch the EUT. After each discharge, the discharge electrode was removed from the EUT. The generator was re-triggered for a new single discharge and repeated 20 times for each pre-selected test point. This procedure was repeated until all the air discharge completed

10.7.2. Contact Discharge:

All the procedure was same as Section 10.7.1. except that the generator was re-triggered for a new single discharge for each pre-selected test point. The tip of the discharge electrode was touch the EUT before the discharge switch was operated.

10.7.3. Indirect discharge for horizontal coupling plane

At least 20 single discharges were applied to the horizontal coupling plane, at points on each side of the EUT. The discharge electrode positions vertically at a distance of 0.1m from the EUT and with the discharge electrode touching the coupling plane.

10.7.4. Indirect discharge for vertical coupling plane

At least 20 single discharge were applied to the center of one vertical edge of the coupling plane. The coupling plane, of dimensions 0.5m X 0.5m, was placed parallel to, and positioned at a distance of 0.1m from the EUT. Discharges were applied to the coupling plane, with this plane in sufficient different positions that the four faces of the EUT are completely illuminated.

10.8. Test Results

PASS.

The EUT was tested and all the test results are listed in next page.

Electrostatic Discharge Test Results

Applicant	Shenzhen Xiaohe Technology Co., Ltd	Test Date	June 8, 2020
EUT	: Spring Sleeping Instrument	Temperature	: 23.5°C
M/N	: AX	Humidity	: 54%
Test Voltage	: DC 5V	Test Mode	: Working
Test Engineer	: Tom	Pressure	: 100.6KPa
Required Performance	: B	Actual Performance	: A

Air Discharge:±8kV # For Air Discharge each Point Positive 10 times and negative 10times discharge.

Contact Discharge:±4kV # For Contact Discharge each point positive 10 times and negative 10 times discharge

For the time interval between successive single discharges an initial value of one second.

Discharge Voltage (kV)	Type of discharge	Dischargeable Points	Performance		Result (Pass/Fai)
			Required	Observation	
±4	Contact	/	B	N/A	Pass
±8	Air	1	B	A	Pass
±2	HCP-Bottom	Edge of the HCP	B	A	Pass
±2	VCP-Front	Center of the VCP	B	A	Pass
±2	VCP-Left	Center of the VCP	B	A	Pass
±2	VCP-Back	Center of the VCP	B	A	Pass
±2	VCP-Right	Center of the VCP	B	A	Pass
±4	HCP-Bottom	Edge of the HCP	B	A	Pass
±4	VCP-Front	Center of the VCP	B	A	Pass
±4	VCP-Left	Center of the VCP	B	A	Pass
±4	VCP-Back	Center of the VCP	B	A	Pass
±4	VCP-Right	Center of the VCP	B	A	Pass

Discharge Points Description

<u>1</u>	Slots	<u>4</u>	
<u>2</u>		<u>5</u>	
<u>3</u>		<u>6</u>	

Test Equipment: ESD Tester PESAX610

Remark:

Discharge was considered on Contact and Air and Horizontal Coupling Plane (HCP) and Vertical Coupling Plane (VCP).

11. RF FIELD STRENGTH SUSCEPTIBILITY TEST

11.1. Test Equipment

Item	Equipment	Manufacturer	Model No.	Serial No.	Last Cal.	Cal. Interval
1.	Signal Generator	Marconi	2031B	11606/058	Sep.19, 18	1 Year
2.	Amplifier	A&R	100W/1000M1	17028	NCR	NCR
3.	Isotropic Field Monitor	A&R	FM7004	0325983	NCR	NCR
4.	Isotropic Field Probe	A&R	FL7006	0325736	Sep.19, 18	1 Year
5.	Laser Probe Interface	A&R	FL7000	325430	NCR	NCR
6.	Power Meter	Anritsu	ML2487A	6k00003262	Sep.19, 18	1Year
7.	Power Sensor	Anritsu	MA2491A	33005	Sep.19, 18	1Year
8.	Log-periodic Antenna	A&R	AT1080	16512	NCR	NCR

11.2. Block Diagram of Test Setup

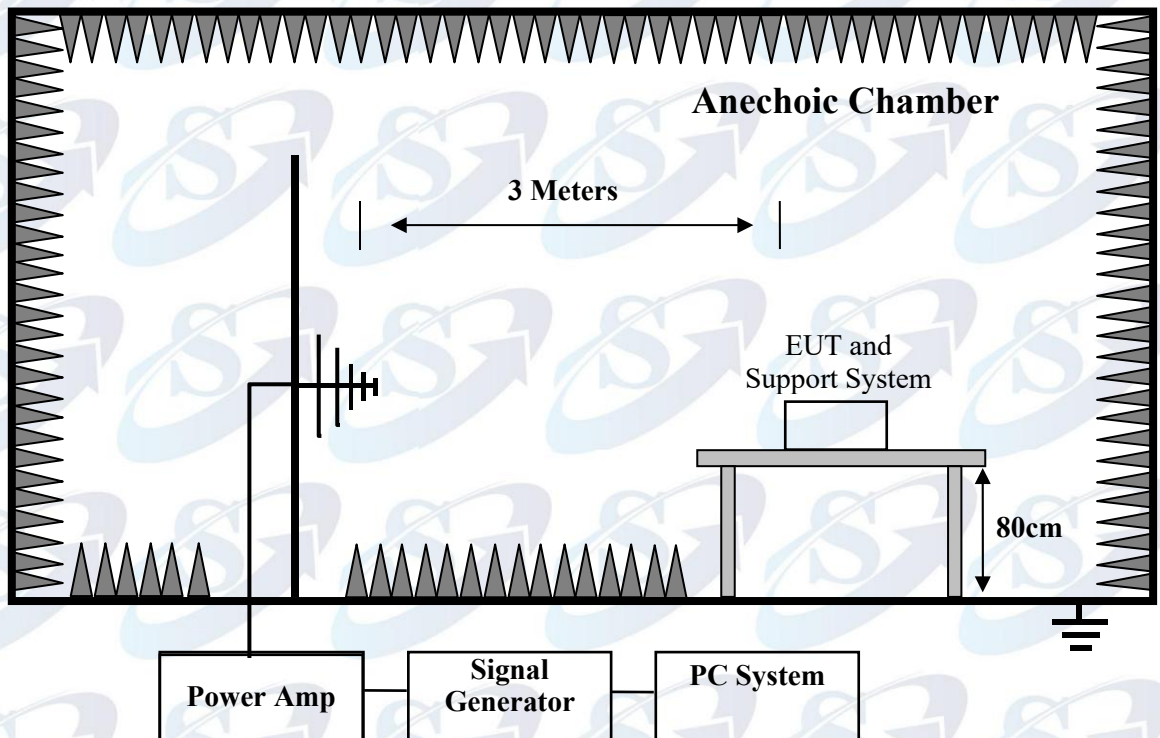

11.3. Test Standard

EN 55014 -2: 2015 (IEC 61000-4-3:2006+A1:2007+A2:2010)
(Severity Level: 2 at 3V / m)

11.4. Severity Levels and Performance Criterion

11.4.1. Severity level

Level	Test Field Strength V/m
1.	1
2.	3
3.	10
X	Special

11.4.2. Performance criterion : **A**

11.5. EUT Configuration

The configurations of EUT are listed in Section 3.5.

11.6. Operating Condition of EUT

Same as Conducted Emission test that is listed in Section 3.6. except the test set up replaced by Section 11.2.

11.7. Test Procedure

Testing was performed in a fully anechoic chamber as recommended by IEC 61000-4-3. The EUT was placed on an 80 cm high non-conductive table located in the area of field uniformity. The radiating antenna was placed 3m in front of the EUT and Support system, and dwell time of the radiated interference was controlled by an automated, computer-controlled system. The signal source was stepped through the applicable frequency range at a rate no faster than 1% of the fundamental. The signal was amplitude modulated 80% over the frequency range 80 MHz to 1GHz at a level of 3 V/m. The dwell time was set at 3 s. Field presence was monitored during testing via a field probe placed in close proximity to the EUT. Throughout testing, the EUT was closely monitored for signs of susceptibility. The test was performed with the antennae oriented in both a horizontal and vertical polarization.

All the scanning conditions are as follows:

Condition of Test	Remarks
1. Test Fielded Strength	3 V/m (Severity Level 2)
2. Radiated Signal	80% amplitude modulated with a 1kHz sine wave
3. Scanning Frequency	80 - 1000 MHz
4. Sweeping time of radiated	0.0015 decade/s
5. Dwell Time	3 Sec.

11.8. TestResults

PASS.

The EUT was tested and all the test results are listed in next page.

RF Field Strength Susceptibility Test Results

Applicant	:	Shenzhen Xiaohe Technology Co., Ltd	Test Date	:	June 8, 2020
EUT	:	Spring Sleeping Instrument	Temperature	:	23°C
M/N	:	AX	Humidity	:	54%
Test Voltage	:	DC 5V	Pressure	:	100.6KPa
Test Engineer	:	Tom	Test Mode	:	Working
Frequency Range	:	80 MHz -1000MHz	Field Strength	:	3V/m
Required Performance	:	A	Actual Performance	:	A
Modulation: <input checked="" type="checkbox"/> AM <input type="checkbox"/> Pulse <input type="checkbox"/> none 1 kHz 80%					
Frequency Range :80 MHz -1000MHz					
Steps	1%				
	Horizontal		Vertical		Result
	Required	Observation	Required	Observation	(Pass / Fail)
Front	A	A	A	A	Pass
Right	A	A	A	A	Pass
Rear	A	A	A	A	Pass
Left	A	A	A	A	Pass
Test Equipment :					
1. Signal Generator : Marconi 2031B					
2. Power Amplifier : A&R 500A/100;100W/1000M.					
3. Power Antenna : A&R AT-1080.					
4. Field Monitor : A&R FM7004.					
Remark: No function loss					

12. ELECTRICAL FAST TRANSIENT/BURST TEST

12.1. Test Equipment

Item	Equipment	Manufacturer	Model No.	Serial No.	Last Cal.	Cal. Interval
1.	EFT Equipment	3ctest	EFT-4001G	20100710 0461015	Sep.19, 18	1 Year

12.2. Block Diagram of Test Setup

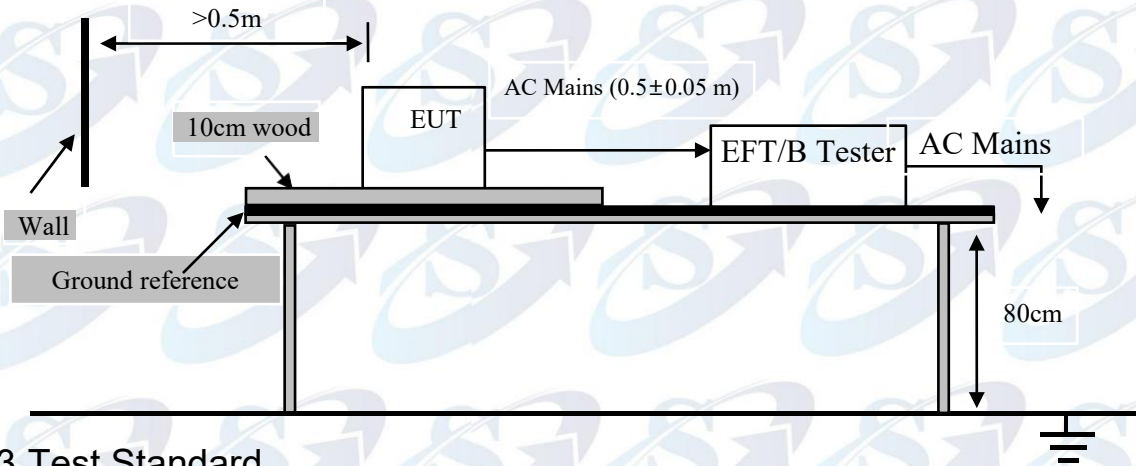

12.3. Test Standard

EN 55014 -2: 2015 (IEC 61000-4-4: 2012)
(Severity Level 2 at 1kV)

12.4. Severity Levels and Performance Criterion

12.4.1. Severity level

Open Circuit Output Test Voltage $\pm 10\%$		
Level	ON Power Supply Lines	ON I/O (Input/Output) Signal data and control lines
1.	0.5 kV	0.25 kV
2.	1 kV	0.5 kV
3.	2 kV	1 kV
4.	4 kV	2 kV
X	Special	Special

12.4.2. Performance criterion : B

12.5. EUT Configuration

The configuration of EUT are listed in section 3.5.

12.6. Operating Condition of EUT

Same as conducted test which is listed in section 3.6. except the test setup replaced by section 12.2.

12.7. Test Procedure

The EUT and its simulators were placed on the ground reference plane and were insulated from it by a wood support $0.1\text{m} \pm 0.01\text{m}$ thick. The ground reference plane was $1\text{m} \times 1\text{m}$ metallic sheet with 0.65mm minimum thickness. This reference ground plane was project beyond the EUT by at least 0.1m on all sides and the minimum distance between EUT and all other conductive structure, except the ground plane was more than 0.5m . All cables to the EUT was placed on the wood support, cables not subject to EFT/B was routed as far as possible from the cable under test to minimize the coupling between the cables.

12.7.1. For input and output AC power ports:

The EUT was connected to the power mains by using a coupling device which couples the EFT interference signal to AC power lines. Both positive transients and negative transients of test voltage was applied during compliance test and the duration of the test can't less than 1min.

12.7.2. For signal lines and control lines ports:

It's not I/O ports.
It's unnecessary to measure.

12.7.3. For DC input and DC output power ports:

It's not DC ports.
It's unnecessary to measure.

12.8. Test Result

The EUT is supplied by battery, so this item does not applicable.

13. SURGE TEST

13.1. Test Equipment

Item	Equipment	Manufacturer	Model No.	Serial No.	Last Cal.	Cal. Interval
1.	Surge Cdn	3ctest	SGN-5010G	EC5591004	Sep.19, 18	1 Year
2	Surge Generator	3ctest	SG-5006G	EC5581006	Sep.19, 18	1 Year

13.2. Block Diagram of Test Setup

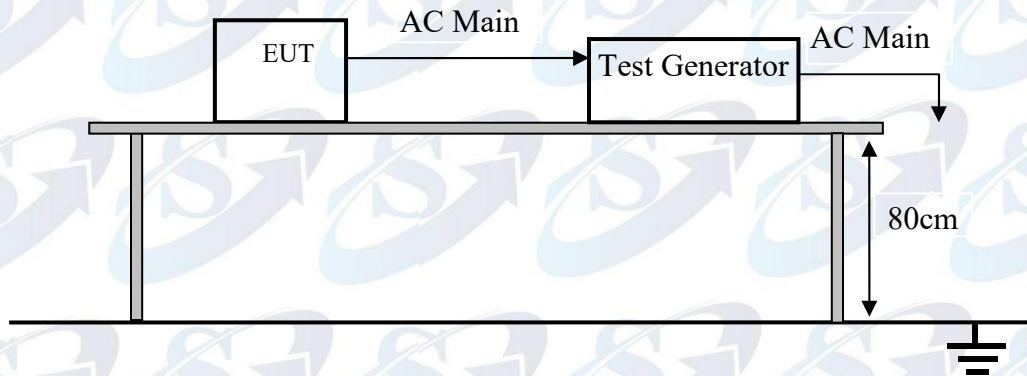

13.3. Test Standard

EN 55014 -2:2015 (IEC 61000-4-5:2014)
 (Severity Level: Line to Line: Level 2 at 1kV
 Line to Ground: Level 3 at 2kV)

13.4. Severity Levels and Performance Criterion

13.4.1. Severity level

Severity Level	Open-Circuit Test Voltage kV
1	0.5
2	1.0
3	2.0
4	4.0
*	Special

13.4.2. Performance criterion : **B**

13.5. EUT Configuration

The configuration of EUT are listed in section 3.5.

13.6. Operating Condition of EUT

Same as conducted test which is listed in section 3.6. except the test setup replaced by section 13.2.

13.7. Test Procedure

- 1) Set up the EUT and test generator as shown on Section 13.2.
- 2) For line to line coupling mode, provide a 1kV 1.2/50us voltage surge (at open-circuit condition) and 8/20us current surge to EUT selected points, and for active line / neutral line to ground are same except test level is 2kV.
- 3) At least 5 positive and 5 negative (polarity) tests with a maximum 1/min repetition rate are applied during test.
- 4) Different phase angles are done individually.
- 5) Record the EUT operating situation during compliance test and decide the EUT immunity criterion for above each test.

13.8. Test Result

The EUT is supplied by battery, so this item does not applicable.

14.INJECTED CURRENTS SUSCEPTIBILITY TEST

14.1.Test Equipment

Item	Equipment	Manufacturer	Model No.	Serial No.	Last Cal.	Cal. Interval
1.	Signal Generator	Marconi	GDN 6000	11606/058	Sep.19, 18	1 Year
2.	Amplifier	AR	25A250A	19152	NCR	NCR
3.	CDN	FCC	FCC-801-M3-25	107	Sep.19, 18	1 Year
4.	PC	N/A	N/A	N/A	N/A	N/A
5.	RF Cable	JINGCHEN G	KLMR400	No.1/2	NCR	NCR

14.2. Block Diagram of Test Setup

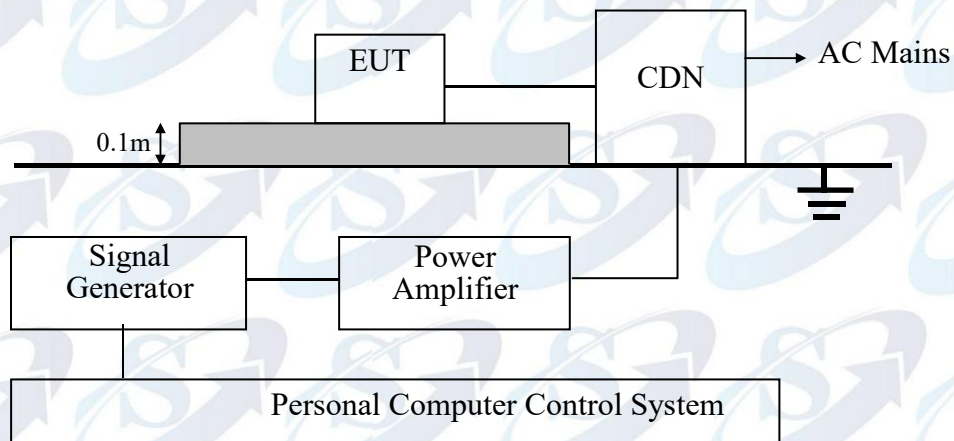

14.3.Test Standard

EN 55014 -2: 2015 (IEC61000-4-6: 2013)

(Severity Level 2 at 3Vrms and frequency is from 0.15MHz to 230MHz)

14.4. Severity Levels and Performance Criterion

14.4.1. Severity level

Level	Voltage Level (e.m.f.) V
1.	1
2.	3
3.	10
X	Special

14.4.2. Performance criterion: **A**

14.5. EUT Configuration

The configuration of EUT are listed in section 3.5.

14.6. Operating Condition of EUT

Same as conducted test which is listed in section 3.6. except the test set up replaced by section 14.2.

14.7. Test Procedure

- 1) Set up the EUT, CDN and test generators as shown on section 14.2.
- 2) Let EUT work in test mode and measure.
- 3) The EUT and supporting equipment are placed on an insulating support 0.1m high above a ground reference plane. CDN (coupling and decoupling device) is placed on the ground plane at above 0.1-0.3m from EUT. Cables between CDN and EUT are as short as possible, and their height above the ground reference plane shall be between 30 and 50 mm (where possible).
- 4) The disturbance signal described below is injected to EUT through CDN.
- 5) The EUT operates within its operational mode(s) under intended climatic conditions after power on.
- 6) The frequency range is swept from 150kHz to 230MHz using 3V signal level, and with the disturbance signal 80% amplitude modulated with a 1kHz sine wave.
- 7) The rate of sweep shall not exceed $1.5 \cdot 10^{-3}$ decades/s. Where the frequency is swept incrementally, the step size shall not exceed 1% of the start and thereafter 1% of the preceding frequency value.
- 8) Recording the EUT operating situation during compliance testing and decide the EUT immunity criterion.

14.8. Test Results

The EUT is supplied by battery, so this item does not applicable.

15. VOLTAGE DIPS AND INTERRUPTIONS TEST

15.1. Test Equipment

Item	Equipment	Manufacturer	Model No.	Serial No.	Last Cal.	Cal. Interval
1.	DIPS Equipment	3ctest	VDG-1105G	20100429 0171002	Sep.19, 18	1 Year

15.2. Block Diagram of Test Setup

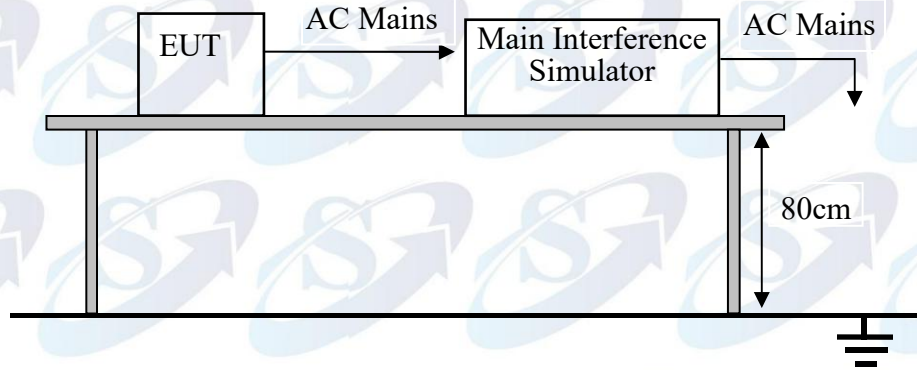

15.3. Test Standard

EN 55014 -2: 2015 (IEC61000-4-11:2004)

(Severity level: 100% 0.5 period
70% 50 periods
40% 10 periods)

15.4. Severity Levels and Performance Criterion

15.4.1. Severity level

Test Level %U _T	Voltage dip and short interruptions %U _T	Performance Criterion	Duration (in period)
0	100	C	0.5
40	60	C	10
70	30	C	50

15.4.2. Performance criterion : C

15.5. EUT Configuration

The configuration of EUT are listed in section 3.5.

15.6. Operating Condition of EUT

Same as conducted test which is listed in section 3.6. except the test set up replaced by section 15.2.

15.7. Test Procedure

- 1) Set up the EUT and test generator as shown on section 15.2.
- 2) The interruptions is introduced at selected phase angles with specified duration. There is a 3mins minimum interval between each test event.
- 3) After each test a full functional check is performed before the next test.
- 4) Repeat procedures 2 & 3 for voltage dips, only the test level and duration is changed.
- 5) Record any degradation of performance.

15.8. Test Result

The EUT is supplied by battery, so this item does not applicable.

16. PHOTOS OF THE EUT

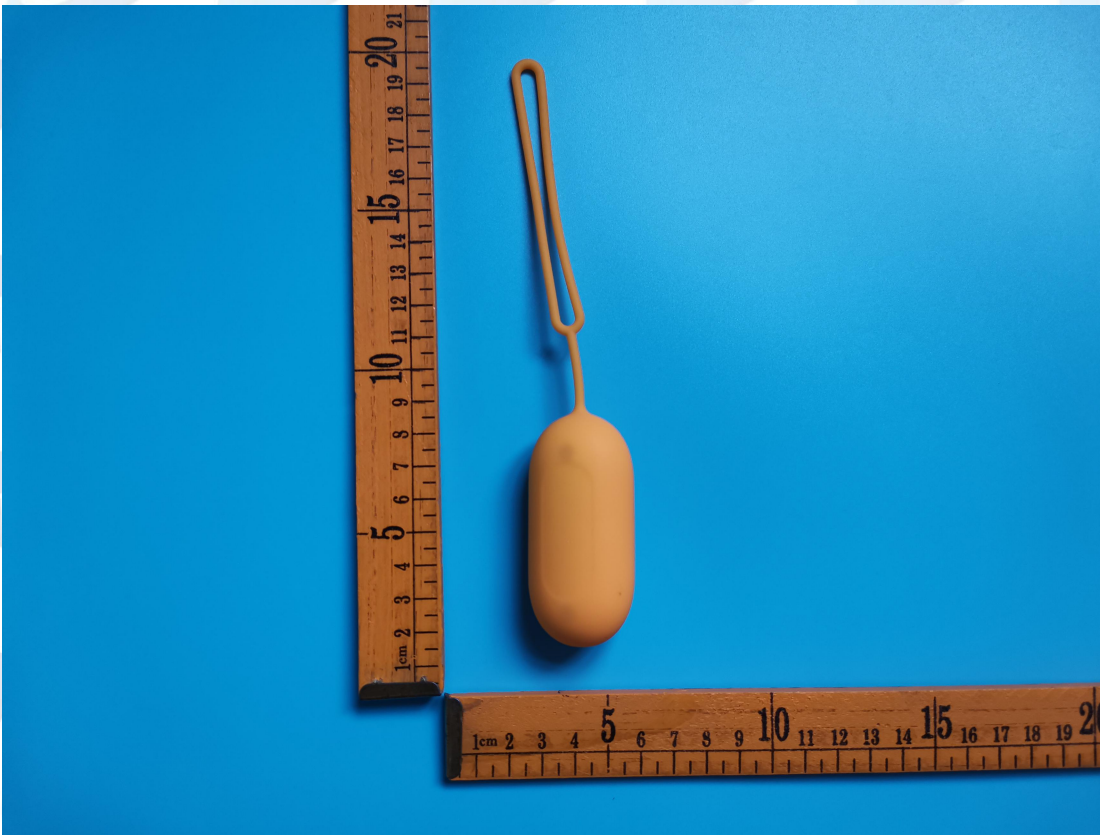

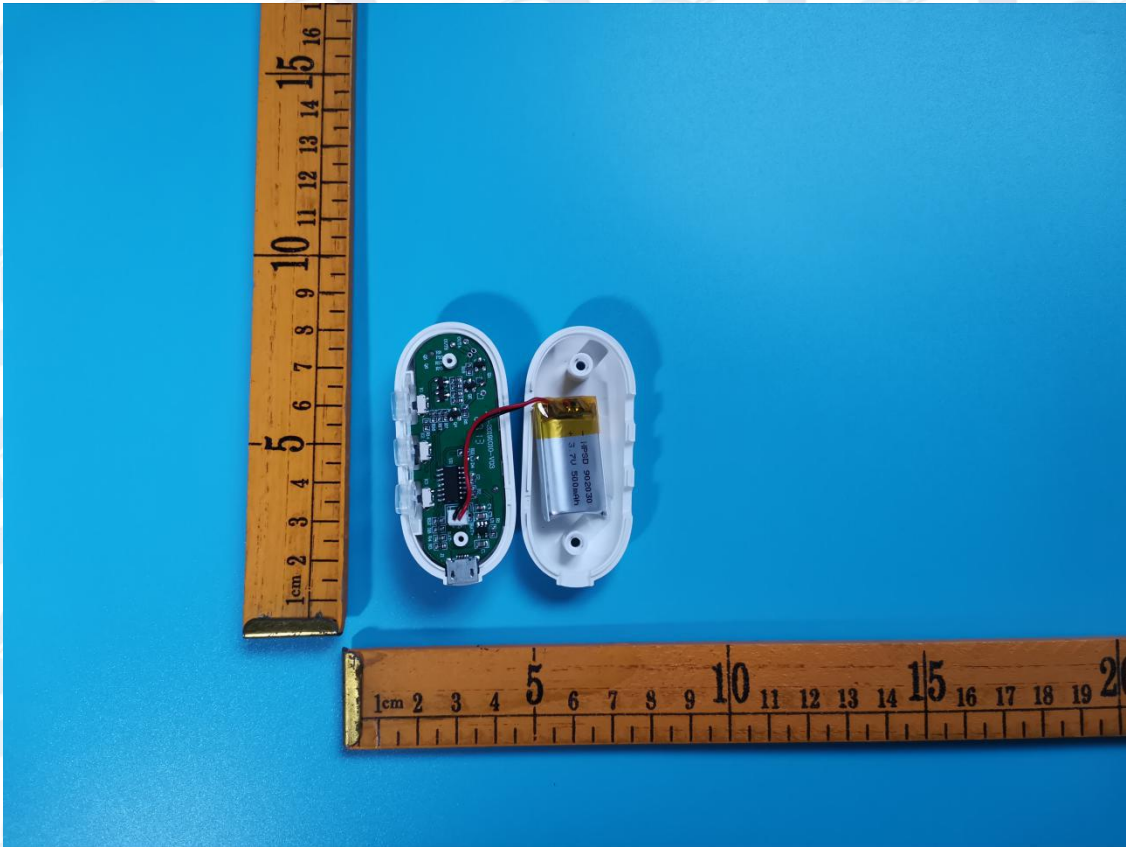

-----THE END OF REPORT-----